

Q1. The diagram shows part of the system used to supply a farm with electricity.

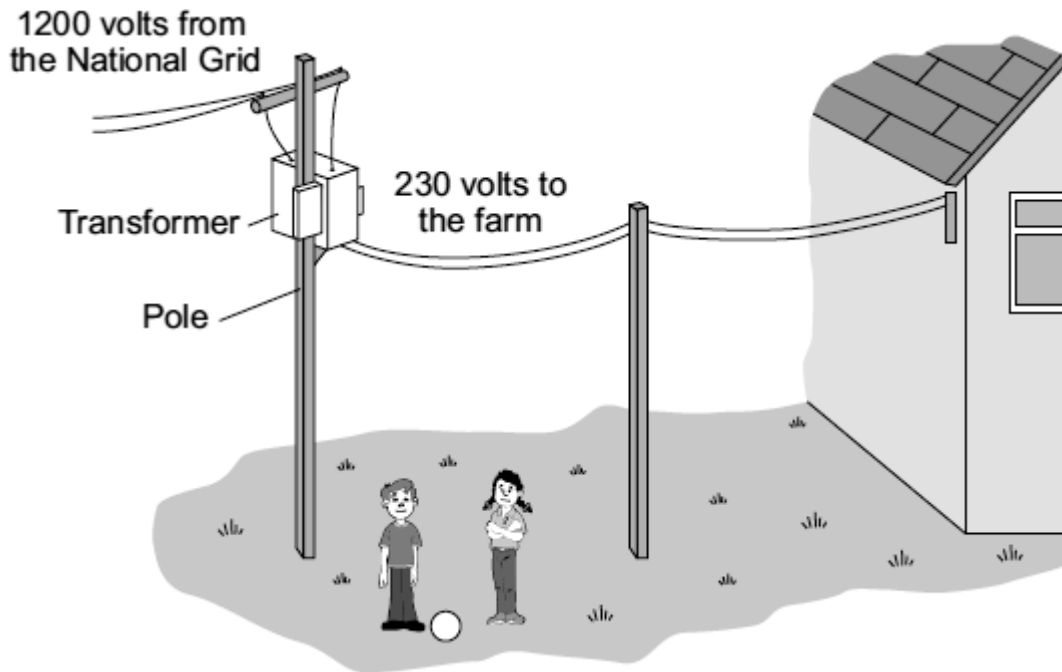

(a) The core of the transformer is made of metal.

Complete the following sentence by drawing a ring around the correct word in the box.

The metal used for the core of the transformer is

- copper.
- iron.
- steel.

(1)

(b) (i) What sort of transformer is shown in the diagram?

.....

(1)

(ii) Complete the following sentence by drawing a ring around the correct line in the box.

In this transformer, the number of turns on the secondary coil is

less than

the same as the number of turns on the primary coil.
greater than

(1)

- (c) Transformers and other electrical equipment can be dangerous.

The following bar chart shows the numbers of children, aged 14 or under, killed or injured in electrical accidents in the UK in 2000, 2001 and 2002.

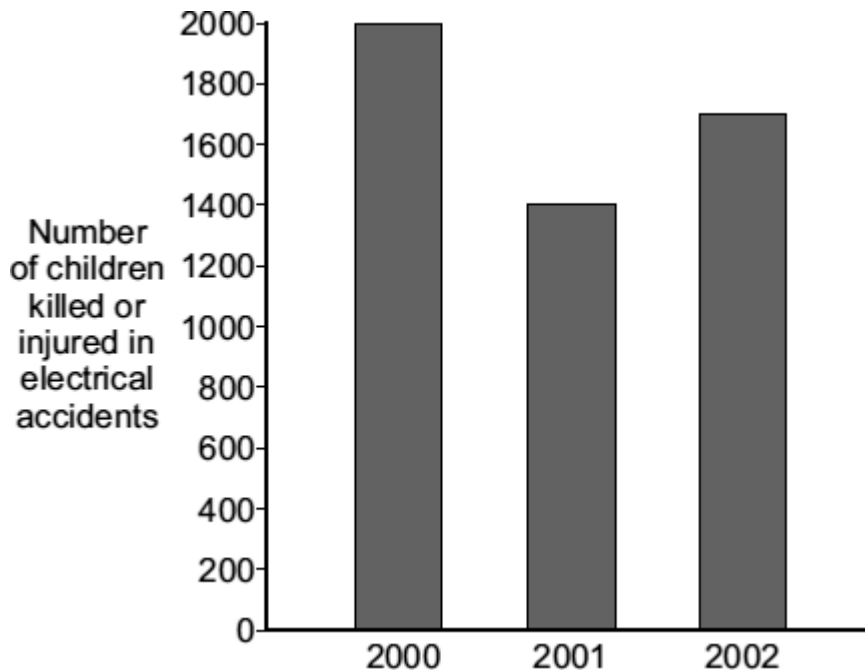

- (i) In which of these years were most children killed or injured in electrical accidents?

.....

(1)

- (ii) A newspaper claims that the number of children killed or injured by electrical accidents will increase in 2011.

Which of the following gives a reason why the information given in the graph does not support this claim.

Put a tick (✓) in the box next to your answer.

The pattern shows an upward trend.

The pattern shows a downward trend.

There is no pattern.

(1)
(Total 5 marks)

Q2. A teacher demonstrates a small transformer.

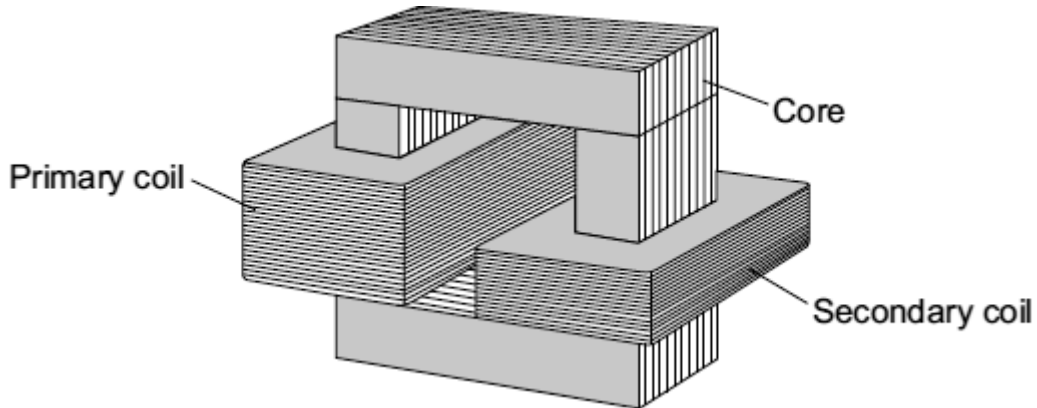

(a) (i) What is the core made of?

Draw a ring around the correct word in the box.

aluminium	copper	iron
-----------	--------	------

(1)

(ii) The potential difference (p.d.) across the secondary coil is less than the p.d. across the primary coil.

What sort of transformer is it?

.....

(1)

(b) Where is a step-up transformer used as part of the National Grid?

.....

(1)

(c) The teacher writes a note about the transformer but leaves **five** spaces.

Use the correct words from the box to complete the spaces.

coil	core	current	ends	field	wire
------	------	---------	------	-------	------

A transformer works because an alternating in the primary produces a changing magnetic in the and then in the secondary coil.

This induces an alternating potential difference across the of the secondary coil.

(5)
(Total 8 marks)

Q3. The figure below shows a coil and a magnet. An ammeter is connected to the coil.

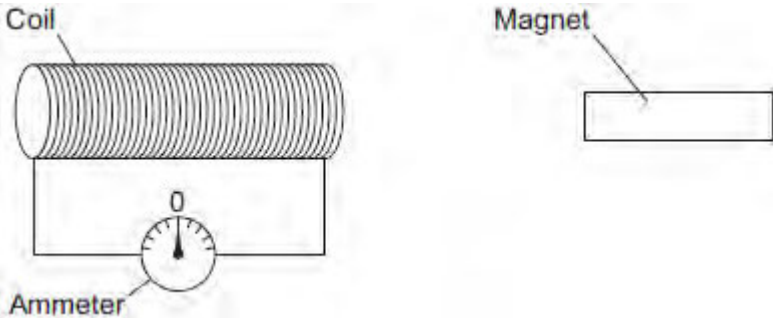

The ammeter has a centre zero scale, so that values of current going in either direction through the coil can be measured.

(a) A teacher moves the magnet slowly towards the coil.

Explain why there is a reading on the ammeter.

.....

.....

.....

.....

.....

.....

.....

.....

.....

.....

.....

.....

.....

.....

.....

.....

.....

.....

.....

.....

.....

(6)

(b) The table below shows some other actions taken by the teacher.

Complete the table to show the effect of each action on the ammeter reading.

Action taken by teacher	What happens to the ammeter reading?
Holds the magnet stationary and moves the coil slowly towards the magnet	
Holds the magnet stationary within the coil	
Moves the magnet quickly towards the coil	
Reverses the magnet and moves it slowly towards the coil	

(4)

- (c) The magnet moves so that there is a steady reading of 0.05 A on the ammeter for 6 seconds.

Calculate the charge that flows through the coil during the 6 seconds.

Give the unit.

.....

.....

.....

Charge =

(3)
(Total 13 marks)

Q4. The diagram shows the design for a remotely controlled door bolt.

When the correct numbers are entered into the keypad the transformer switches on. Then the door can be opened.

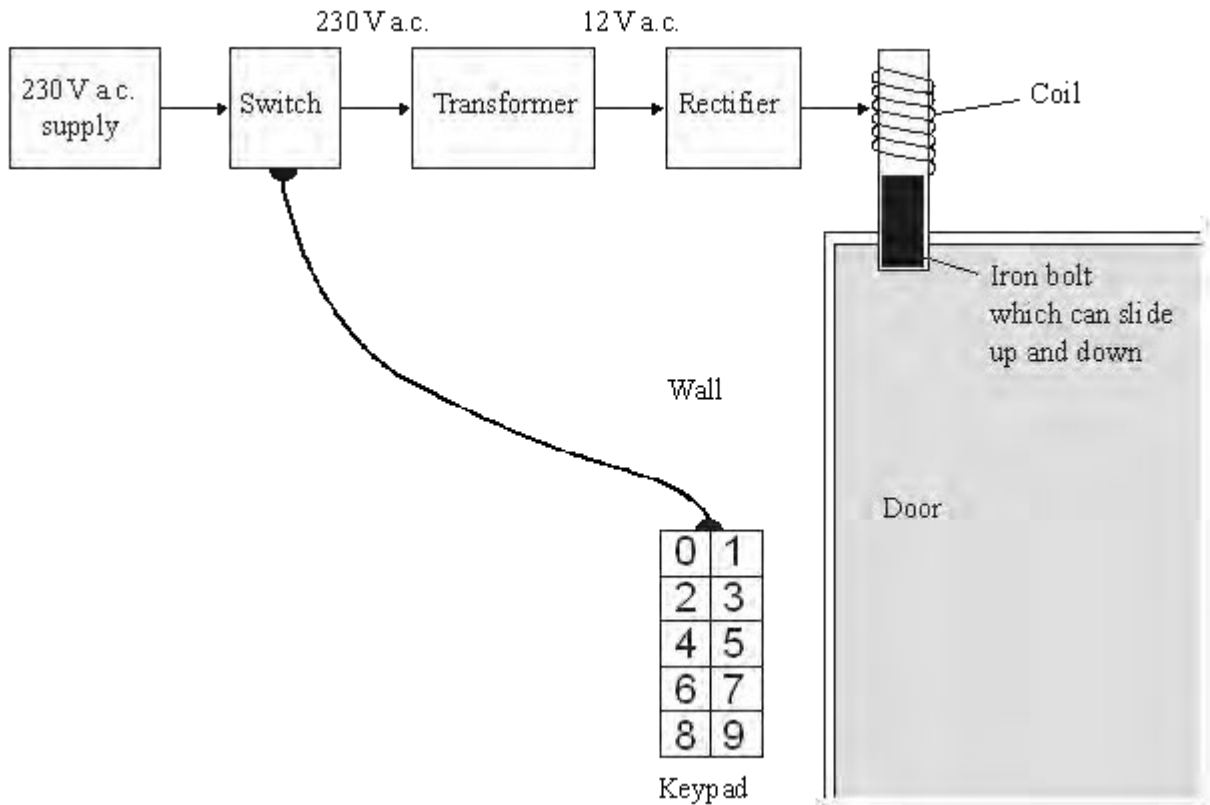

(a) What kind of transformer is shown in the diagram?

.....

(1)

(b) What does the abbreviation a.c. stand for?

.....

(1)

(c) Complete the sentences using the correct words from the box.

attracts	downwards	magnet	reflects	repels
----------	-----------	--------	----------	--------

sideways switch transformer upwards

- (i) When a current flows in the coil, the coil becomes a
- (ii) The coil the iron bolt which moves

(3)
(Total 5 marks)

Q5.(a) The diagram shows the structure of a traditional transformer.

Use words from the box to label the diagram.

aluminium	brass	iron	large	primary	secondary
-----------	-------	------	-------	---------	-----------

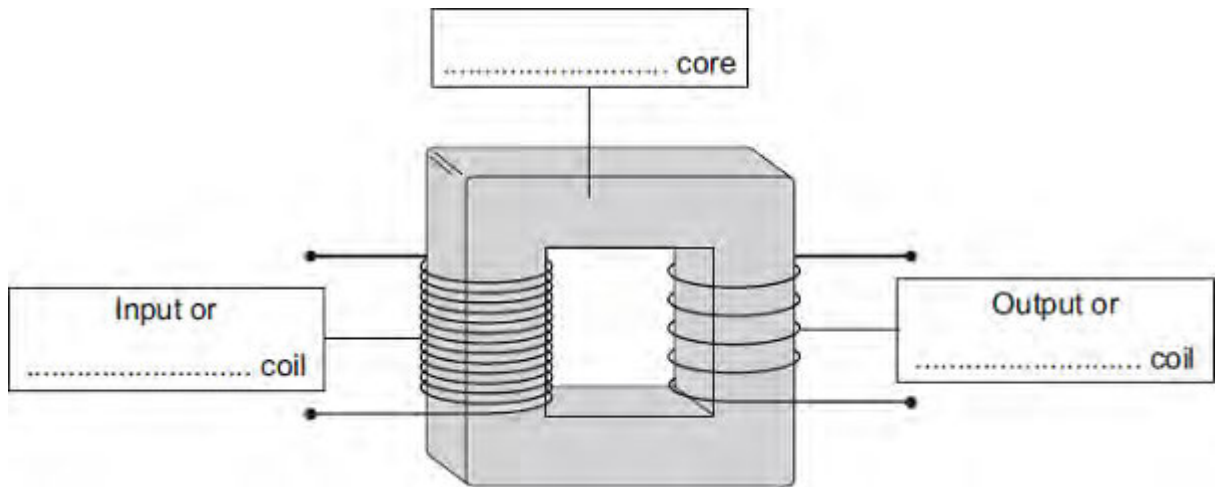

(3)

(b) Batteries inside laptop computers are charged using laptop chargers. The laptop charger contains a traditional transformer.

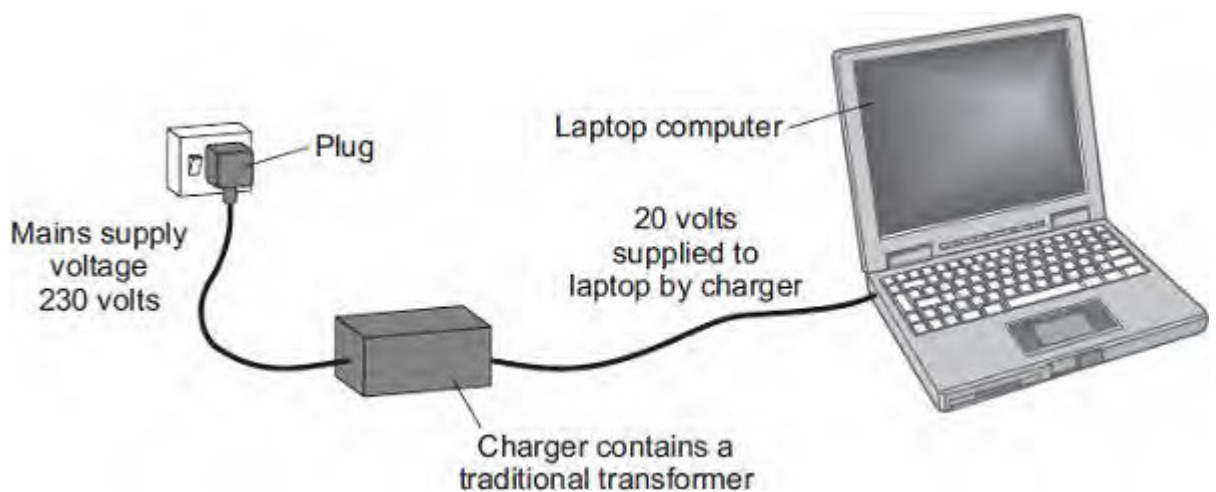

The laptop charger contains a step-down transformer.

What does a step-down transformer do?

.....

.....
(1)

- (c) Laptop batteries and mobile phone batteries can only be recharged a limited number of times. When a battery cannot be recharged, it is better to recycle the battery than to throw it away.

Draw a ring around the correct answer to complete the sentence.

The batteries are recycled mainly due to

an environmental
a political
a social

 consideration.

(1)
(Total 5 marks)